

MANUAL TOILETS: -New Compact Model -New Comfort Model



This toilet may be supplied in the standard and large bowl versions and is equipped with a new conceiving of manual toilet pump offering the following qualities:

- Thanks to the proper button hole-shaped fixing holes on the base, it is possible to replace the toilet without having to bore new holes (easy substitution with toilets by PAR, RM and many others) to do so.
- All mouldings are made of a kind of plastic material fully resistant against uric acids as well as against the chemical agents contained in the detergents which are normally employed to keep the toilet clean.
- The complete opening from top of the piston allows a quick cleansing without disassembling the toilet from the base.
- The toilet may be mounted both above and below the waterline. The pump is a self-priming one.
- The reversible left- handed pump mounting enables to install the toilet indifferently on both sides.
- Waste discharge is possible both overboard and into holding tanks on board.
- The toilet is equipped with luxury baked enamel painted wooden seat and cover

Fitting details: Connections for 19 mm. (3/4") inlet hose and 38 mm. (1 1/2") outlet hose

Dimensions: Standard: width cm. 45 x depth cm. 41 x height cm. 34 (17 3/4" x 16" x 13 1/2")

Weight: Standard model: kg. 10 about

CD: 6600000700 - equipped with wooden seat

CD: 6600200700 - equipped with plastic seat

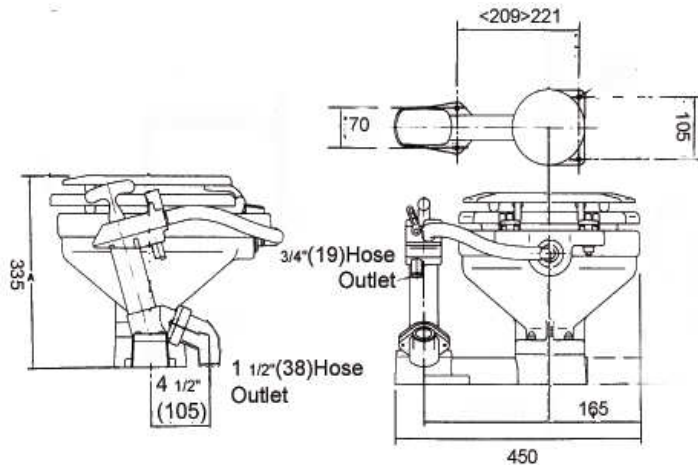

Fitting details: Connections for 19 mm. (3/4") inlet hose and 38 mm. (1 1/2") outlet hose

Dimensions: width cm. 47 x depth cm. 48 x height cm. 35 (18 1/2" x 19 x 13 3/4")

Weight: Kg. 11 about

CD: 6600000800 - equipped with wooden seat

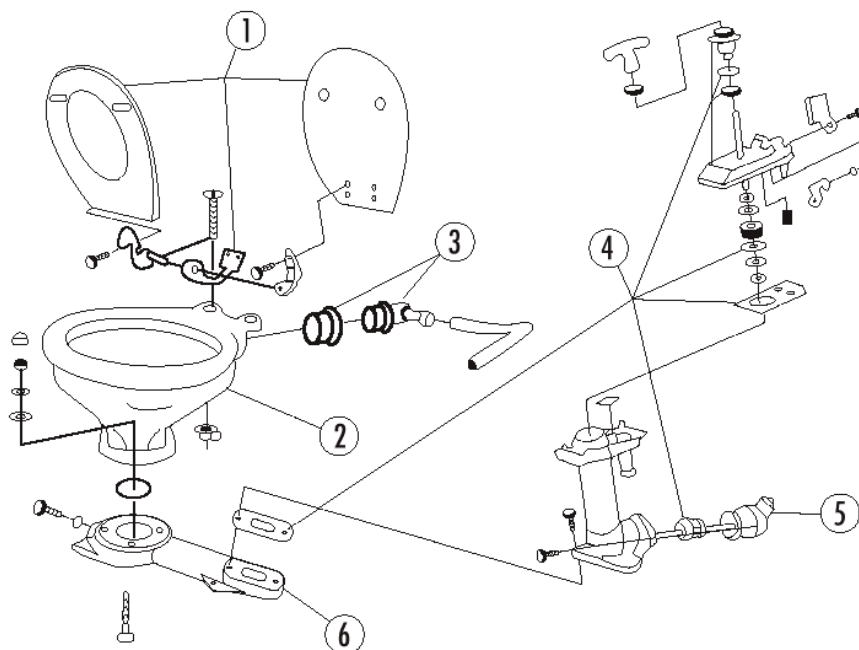
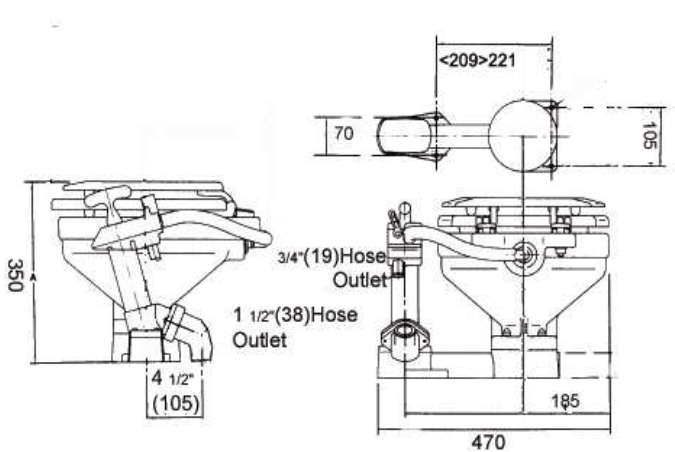

SPARE PARTS:

ART. 6500000001 WHITE WOODEN SEAT (1)

ART. 6500000500 COMPACT PORCELAIN BOWL (2)

ART. 6500000550 INTAKE ELBOW (3)

ART. 6500011000 GASKET KIT (4)

ART. 6000000706/7/11 OUTLATE/FLANGE ELBOW/GASKET (5)

ART. 6100000777 TOILET BASE (6)

The large toilet bowl has the following code ART 6500000510

OPERATING INSTRUCTIONS

INTRODUCTION: The toilet is one of the most employed equipment on your boat. A correct operation of the toilet is essential for the safety and the comfort of your crew and your craft.

HAZARD RISK: ACCIDENTAL DAMAGE : If the toilet is connected to any through-hull fittings and if either the toilet or the pipework is damaged, water may flood in, causing the craft to sink, which may result in loss of life. Therefore, after each usage, both seacocks (or secondary valves) must be shut. Whenever your craft is unattended, even if only for a very short period of time, both seacocks (even if secondary valves are fitted) must be shut.

- Ensure that all users understand how to operate the toilet system correctly and safely, including seacocks or secondary valves.

- Take special care to instruct children, the elderly and the visitors.

ABSOLUTELY SHUT SEACOCKS!

1. **FIRST USE:** After periods without use, the toilet may benefit from lubrication.

- Open inlet and outlet seacocks (as well as secondary valves, if any)

- Half-fill the bowl with warm fresh water containing a few drops of vegetable oil or baby oil

- Keeping the flush control lever in the "Shut position", pump out the warm water

2. **NORMAL USE** Open inlet and outlet seacocks (and secondary valves if fitted)

- Before use, ensure that there is enough water in the bowl to prevent the toilet paper from becoming compacted at the bottom of the bowl

If the bowl is empty, move the flush control lever to the "Open" position and pump the handle up and down, until the flushing pump is primed and water enters the bowl Then, shut the flush control.

- Operate the pump with long, smooth strokes for efficient and easy operation

- During use, pump as necessary as to keep the contents of the bowl low enough for comfort.

- Use good quality hard or soft household toilet paper, but do not use more than necessary

- After use, keep the flush control shut and pump until the bowl is empty

When the bowl is empty, open the flush control again and continue to pump until all waste has either left the boat, or has reached the holding tank ((allow 7 complete up and down strokes per metre length of discharge pipework

Afterwards, shut the flush control and pump until the bowl is empty. Always leave the bowl empty to minimise odour and spillage.

AFTER USE:- SHUT THE FLUSH CONTROL - CLOSE BOTH SEACOCKS

Warning: DO NOT PUT anything such as **SANITARY NAPKINS, WET TISSUES, COTTON WOOL, CIGARETTES, MATCHES, CHEWING GUM OR ANY SOLID OBJECT, PETROL, DIESEL, OIL AND SOLVENTS INTO THE BOWL**

3. **CLEANING** A regular flushing with clean sea-water represents one of the most effective methods to keep the toilet clean and sweet smelling.

- To clean the bowl, use any liquid or cream ceramic cleaner

- To clean the rest of the toilet, including seat and lid, use a non-abrasive liquid cleaner.

Then polish with a dry cloth only. **Caution: DO NOT USE ABRASIVE PADS ON ANY PART OF THE TOILET AND DO NOT USE CREAM CLEANERS EXCEPT FOR THE BOWL**

- To disinfect the toilet, use a liquid disinfectant diluted in accordance with the Manufacturer's instructions. It is possible to apply it to all parts of the toilet using a sponge or a soft brush **Caution: DO NOT USE THICK LIQUID TOILET CLEANERS OR NEAT BLEACH** because they might damage the valves, gaskets and seals.

- After applying any cleaning or disinfecting agent, always flush well **Caution: DO NOT ALLOW THESE AGENTS TO STAND IN THE SYSTEM.**

- **THROUGH-HULL FITTINGS** You will need a 19 mm. (3/4") bore seacock for the flushing water inlet and, if you are discharging overboard, a 38 mm. (1 1/2") bore seacock for the waste outlet.

- Keep to the seacock manufacturer's instructions concerning materials and methods of installation Ensure that the inlet seacock is positioned where it will be below the waterline at all times when the craft is under way and also ensure that any outlet seacock is both aft of, and higher than the inlet seacock

4. **PIPEWORK** - selection of the correct method: You must select the correct installation method for the inlet pipework from 2 possibilities and for the outlet pipework from 4 possibilities, according to whether the toilet is above or below the waterline and to whether it discharges the waste overboard or into an on-board holding tank.

4.1 **General instructions for all Possibilities** You will need a spiral reinforced smooth bore flexible hose for both the 19 mm. (3/4") internal diameter inlet and the 38 mm. (1 1/2") internal diameter outlet hose and a stainless steel hose clip.

- secure the hose runs so that the hoses cannot move, nor exert any leverage action on the hose tail fittings to which they are connected, as this may cause adjacent joints to leak

- avoid sharp bends in the hoses since this might cause them to become kinked

- keep all pipework lengths as short as possible while you are carrying out these operations

- unnecessary inlet or outlet hose lengths just make the toilet harder to pump

- should it be difficult to fit the hose onto the hose tails of the toilet or the seacocks, soften the hose by dipping its end in hot water

Caution: DO NOT APPLY FLAME TO HOSES DO NOT APPLY FLAME OR HEAT TO THE PLASTIC HOSE TAILS OF THE TOILET DO NOT APPLY SEALING COMPOUNDS TO ANY HOSE CONNECTION

- Secure all hose ends to the hose tails with stainless steel clips, ensuring that all inlet connections are airtight and that all outlet connections are watertight

- The discharge elbow may be rotated 360 deg. to suit your installation. Always slacken the 2 securing screws, adjust the discharge elbow to the required position and retighten the 2 securing screws before connecting the hose to it **Caution: FAILURE TO FOLLOW THIS PROCEDURE MAY CAUSE LEAKS BETWEEN THE ELBOW AND THE PUMP CYLINDER**

4.2 **Toilet below the waterline:** You will need a 19 mm. (3/4") Vented Loop fitting.

- run the inlet hose by the most direct way from the inlet seacock to the flushing pump inlet tail

- remove the white hose supplied with the toilet which connects the flushing pump outlet tail to the bowl elbow

- using a spanner, rotate the intake seal so that the elbow points upwards

- replace the white hose with a longer length of 19 mm. internal diameter hose and position it in a way that its point is at least 20 cm. (8") above the highest possible waterline and fit the vented loop at that highest point

Caution: DO NOT POSITION THE VENTED LOOP BETWEEN THE INLET SEACOCK AND THE FLUSHING PUMP INLET, as it will make the flushing pump difficult or harder to prime, and could prevent it from working at all.

Toilet above the waterline: You may need a 19 mm. (3/4") non-return valve

- run the inlet hose by the most direct route from the inlet seacock to the flushing pump inlet tail

- for your maximum convenience of use, install an in-line non-return valve next to the inlet seacock which will ensure that the pump stays primed in between usages

- the toilet flushing pump will self-prime up to 1 metre (3') above the outside water level. If there is any possibility that the toilet flushing pump

4.3 Toilet below the waterline and discharging overboard: You will need a 38 mm. (1 1/2") Vented Loop fitting

- Arrange the outlet hose, so that its highest point is at least 20 cm. (8") above the waterline, and fit the Vented Loop in that point

4.4 Toilet above the waterline and discharging overboard: You may need a 38 mm. (1 1/2") Vented Loop fitting

- Run the outlet hose up from the discharge elbow, at least 30 cm. (12") above the discharge elbow. Then fit a Vented Loop on top of the hose, ensuring in this way to keep some water in the base of the toilet without risk of it being siphoned away.

4.5 Toilet waste discharging into holding tank. Discharge elbow below top of holding tank at any time: You will need a 38 mm. (1 1/2") Vented Loop fitting

- if the discharge elbow is placed less than 203 mm. (8") above the top of the holding tank when the craft is at rest, or if there is any possibility that the discharge elbow may be below the top of the tank at any time, a vented loop must be fitted in the outlet pipework

- Place the outlet hose point at least 203 mm. (8") above the highest level that the top of the tank may reach and install the Vented Loop fitting on this highest point

4.6 Toilet waste discharging into holding tank, discharge elbow always above top of the holding tank: You may need a 38 mm. (1 1/2") Vented Loop fitting

- Run the inlet hose upwards from the discharge elbow, to form a loop at least 30 cm. (12") higher than the discharge elbow

- By fitting a Vented Loop on top of the hose loop, you will ensure to keep some water in the base of the toilet without risk of it being syphoned away.

5. TESTING: Refer to the operating instructions and follow the procedures for normal use. In case the flushing pump is hard to prime, half-fill the bowl with fresh water

6. SAFETY: Ensure that these instructions reach the owner, the skipper or the operator of the craft, as it contains important safety information.

ON COMPLETION OF INSTALLATION: SHUT THE FLUSH CONTROL! CLOSE BOTH SEACOCKS!

INSTALLATION INSTRUCTIONS

Introduction: If the installation of the toilet results in being connected to any through-hull fitting that may possibly be below the waterline whether when the craft is at rest or underway or heeling, rolling or pitching, you must install the toilet in accordance with the present installation instructions. Failure to follow such instructions may cause water to flood in, which may result in loss of life

ACCIDENTAL DAMAGE: If the toilet is connected to any through-hull fitting and if the toilet or the pipework are damaged, water may flood in, causing the craft to sink with a consequent possible loss of life. For this reason, if you are making connections between the toilet and any through-hull fitting that may be possibly situated below the waterline, fullbore seacocks must be fitted to such hull-fittings, to allow them to be shut off.

The seacocks must also be positioned where they are easily accessible to all users of the toilet. If, for any reason, it is not possible to do it, then secondary full-bore marine quality valves must be fitted to the hoses where they are easily accessible. **USE SEACOCKS! Caution: USE LEVER OPERATED, FULL-BORE MARINE SEACOCKS AND VALVES. THE USE OF SCREW-DOWN GATE VALVES IS NOT RECOMMENDED.**

PIPEWORK LOOSING: All pipeworks must be fastened both in the gate side and in the remaining ones with a stainless steel hose clamp. Please keep in mind that an eventual leak might cause the craft to sink, with consequent loss of life. **USE HOSE CLAMPS!**

BOWL RIM BELOW THE WATERLINE: If the toilet is connected to any through-hull fitting and if the rim of the bowl falls below the waterline, water may flood in, causing the craft to sink, which may result in loss of life. Therefore, if the rim of the toilet is less than 20 cm. (8") above the waterline when the craft is at rest, or if there is any possibility that the rim of the bowl may be below the waterline at any time, a vented loop must be fitted in any pipework connected to a through-hull fitting, irrespective of whether inlet or outlet. **USE VENTED LOOPS!**

Special notes: The smaller bore inlet pipework is more dangerous than the larger outlet one. Unless there is a ventilated anti-syphon loop in the inlet pipework, water will flow into the bowl whenever both the inlet seacock is opened and the rim of the bowl is below the actual waterline. Although moving the flush control lever to the "Shut" position will restrict the flow, this lever cannot be relied upon as a safety device. To make a loop in the hose without mounting a vent may be as hazardous as no loop at all, because water will syphon over the loop.

IN FACT, IT IS THE VENT THAT ACTUALLY PREVENTS THE SYPHON

1. LOCATION: The toilet is supplied assembled for a right handed operation. If you wish, both standard and large bowl models may be reassembled with the pump positioned on the left hand side.

- choose a location which will give enough clearance all around and above the toilet. Ensure that there is room to operate the pump and that there is access to the drain plug at the end of the base.

- the mounting surface must be flat, rigid, and strong enough to support a man's weight and should be at least 50 mm. (2") wider and 50 mm. (2") deeper than the base of the toilet.

- you will need sufficient clearance below the mounting surface to be able to secure the mounting bolts.

- the seat and the lid should be able to swing open at least 110 degrees, in order they will not fall forward when the craft heels or pitches.

When they are swung open, they must be supported so that the hinges are not strained.

2. MOUNTING: You will need 4 x 8 mm. (5/16") diameter bolts of length to suit the thickness of the mounting surface, 4 nuts, preferably self-locking, 8 large washers not more than 21 mm (13/16") diameter, all in marine grade stainless steel or bronze, and a small tube of silicone sealant.

If you do not use self-locking nuts, you will need some nut-locking compound.

- Offer up the toilet in the selected position and, using the holes in the base as a guide, mark the position for the 4 bolt holes on the mounting surface, remove the toilet and drill 4 vertical holes of 9 mm. diameter through the mounting surface

- Apply a bead of silicone sealant to the outer rim of the base bottom

- Bolt down the toilet and tighten fastenings securely. If you are not using self-locking nuts, apply a nut-locking compound to the bolts (**picture 2 and 3**)

MAINTENANCE INSTRUCTIONS

INTRODUCTION: Our manual toilets normally do not require maintenance during the season, provided that they are winterised in the autumn and overhauled in the spring : However, any toilet will benefit from: thorough flushing (refer to the operating instructions for normal use. Regular use) if not regularly used, lubrication is beneficial (refer to the operating instructions for the first use)

HAZARD RISK: LEAKS :If the toilet is connected to any through-hull fittings, and if the toilet or the pipework develops a minor leak, this leak can suddenly become a bigger leak which will allow water to flood in, causing the craft to sink, with subsequent loss of property and life. So, **IN CASE ANY LEAK DEVELOPS, REPAIR IT IMMEDIATELY! MOREOVER, REGULARLY INSPECT ALL FASTENINGS TO CHECK TIGHTNESS AND LEAKS.**

1. SERVICING: Preparation. Our manual toilets are user serviceable and no special skills or tools are required to employ them.

- Flush the toilet according to the operating instructions for normal use and particularly ensure that all waste has left the discharge pipework, that the bowl is empty and that both seacocks are closed (even though secondary valves are fitted)

- Mop-up any water which might come out of the system

2. SERVICING: seal replacement. If water begins to leak round the piston rod on top of the pump, it means that the seal assembly is worn out and should be replaced. To this purpose, you will have to act as follows:

- You will need a service kit

- Raise the handle to the top of its travel and wrap one turn of tape around the piston rod immediately below the handle. Using pliers, grip the

- Unscrew the seal assembly and slide it off the piston. Wrap one turn of tape around the thread at the top of the piston rod to protect the new seal, slide the new seal down the piston rod and tighten it. Remove the tape from the thread. Replace the bumper washer and the handle, absolutely by gripping the piston rod through the tape.

Then remove the tape from the piston rod.,

3. SERVICING: Winterization. Drain the complete system both as a protection against frost damage and to avoid the growth in the pipework of bacteria that could cause unpleasant smells. Warning: THE USE OF ANTI-FREEZE IS NOT RECOMMENDED, as it is not possible to ensure that the product penetrates the whole toilet system. If, for any reason, an anti-freeze compound is employed, it will have to be a glycol-based one.

- open any secondary valve - remove the base drain plug

- Loosen hose clips and disconnect all the hose ends from the seacock hose tails, the hose toilet tails, and any secondary valves

Pump the handle to drain the toilet pump and ensure that all water is properly drained from the toilet system

HAZARD RISK: SEACOCKS OPENED BY MISTAKE. In case you leave the toilet disassembled and if the seacocks are opened when the boat is afloat, water will flood in by causing the sinking of the boat and the possible loss of life. Therefore, it is indispensable to attach a warning notice to the seacocks and, if possible, wire the seacocks shut. REMEMBER TO ATTACH WARNING NOTICES! If you are not disassembling the toilet:

- reconnect all hose ends and secure them with their hose clips

- firmly replace the base drain plug

- fasten down seat, lip and pump handle to prevent any use, and attach a warning notice

4. SERVICING: Overhaul. You will need a service kit containing all wearing parts -

refer to the list of parts for further details. Caution: FOR THE SAFETY OF YOUR CRAFT AND YOUR CREW, USE

ONLY GENUINE SPARE PARTS. Remove the pump assembly as follows:

- loosen hose clips, disconnect the inlet hose and the link hose from the top of the pump

- remove the 2 screws which secure the discharge flange to the pump cylinder

- remove the 4 screws which secure the pump cylinder to the base

- lift off the pump assembly and pick up the bottom valve gasket and the joker valve

Dismantle the Pump assembly as follows:

- remove the 6 screws that secure the valve cover

- open the flush control before lifting off the valve cover assembly and picking up the top valve gasket and the valve seat

Reassemble the pump as follows:

- Push on the new piston O-ring

- Follow the servicing instructions for seal replacement and fit the new seal assembly, the piston assembly and the handle

- Lubricate pump cylinder bore with Vaseline

- Locate the valve seat on cylinder top, locate the top valve gasket on its pegs on the cylinder top and open the flush control before refitting the valve cover

Refit Pump assembly on the toilet as follows:

- Locate the bottom valve gasket on its pegs on the base and locate the joker valve in the discharge elbow

- Secure the discharge flange to the pump cylinder before securing the cylinder to the base

- Examine all hoses throughout their length for chafe, kinks and splits under hose clips, check all hose clips for corrosion and replace worn out or damaged parts Reconnect all hose ends and secure them with their hose clips Ensure that the base drain plug is securely placed

5. TESTING: Refer to the operating instructions and follow the procedure for normal use.

- if the flushing pump results to be hard to prime, half-fill the bowl with fresh water

